



IF flat-bed scales



- Easy handling due to ergonomic design and sophisticated equipment
- Ideal for clean rooms in the pharmaceutical industry, for example, as they are designed with hygiene aspects in mind
- Suitable for operation with aggressive substances due to the use of resistant materials
- Very easy wet cleaning e.g. in wet production facilities in the food industry
- Freely moveable due to rollers and steering drawbar
- Low maintenance costs and long service life due to robust construction

(picture shows IF platform incl. optional accessories)

General specifications

IFP:

- Steel, painted (colour: RAL7030)
- IP Protection rate: IP65
- for use in hazardous area zone 2 and 22 with option Y2
- ATEX: II 3 GD EEx nA II T6 T80°C

IFS:

- Stainless steel AISI 3041
- IP Protection rate: IP68
- optionally with electro polished stainless steel load plate AISI 3041 or AISI 316 Ti
- for use in hazardous area zone 2 and 22 with option Y2
- ATEX: II 3 GD EEx nA II T6 T80°C

IFXS:

- Stainless steel AISI 3041
- IP Protection rate: IP69K
- optionally with electro polished stainless steel load plate AISI 316 Ti or in tread plate version
- for use in hazardous area zone 1 and 21
- ATEX: II 2 GD EEx ib II C T4 T150°C

Cable length

6 m, mounted on the weighing platform (as standard)

Temperature range

-10 ... +40 °C

Resolution

Verifiable in class III (1x3,000e, 2x3,000e) or non-verifiable

Others

4 x adjustable leveling feet, leveling equipment

По вопросам продаж и поддержки обращайтесь:

Астана+7(7172)727-132, Волгоград(844)278-03-48, Воронеж(473)204-51-73, Екатеринбург(343)384-55-89,
Казань(843)206-01-48, Краснодар(861)203-40-90, Красноярск(391)204-63-61, Москва(495)268-04-70,
Нижний Новгород(831)429-08-12, Новосибирск(383)227-86-73, Ростов-на-Дону(863)308-18-15, Самара(846)206-03-16,
Санкт-Петербург(812)309-46-40, Саратов(845)249-38-78, Уфа(347)229-48-12

sst@nt-rt.ru || sartorius.nt-rt.ru

Example Order Code:

IF	P	4	1500	RR	L
Platform	Design: P = Painted steel S = Stainless steel XS = EX protection, Stainless steel	Quantity Weigh cells 	Weighing ranges in kg	Weighing platform size	Resolution: Non-verifiable 15,000 d = L 30,000 d = I verifiable 3,000 e = LCE 2 × 3,000 e = NCE

Scale drawings

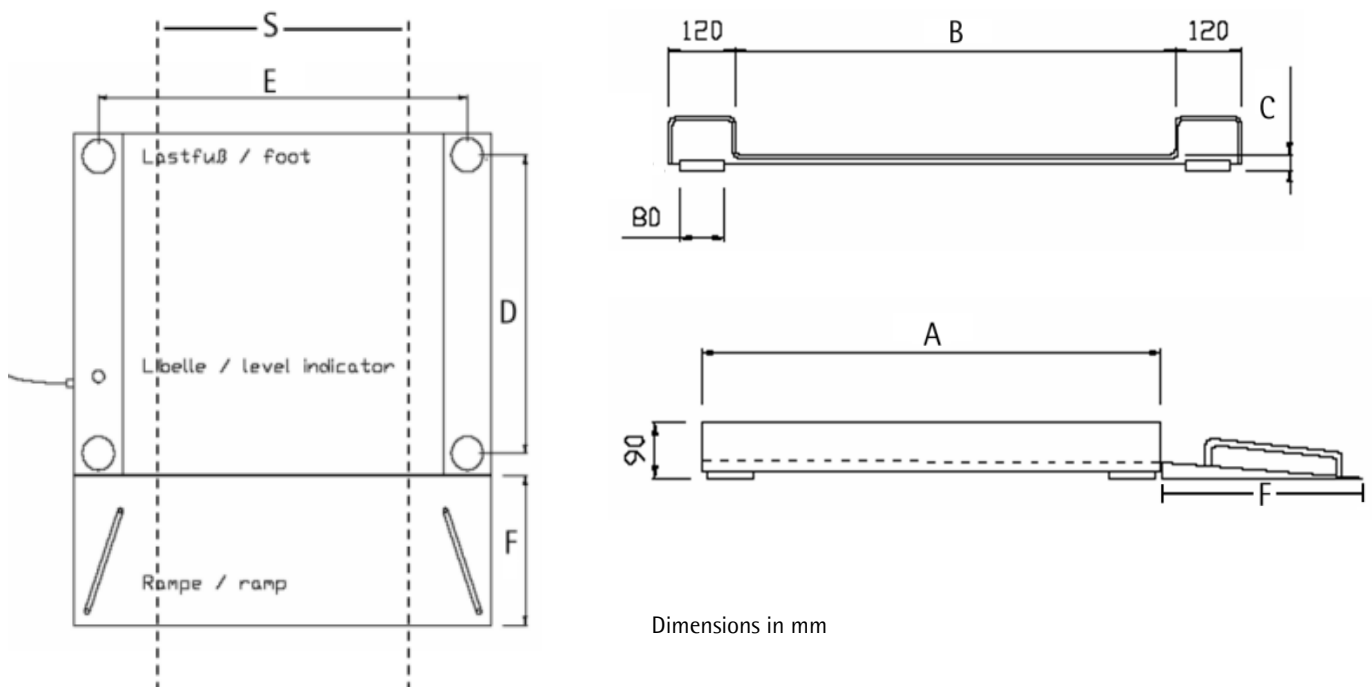

Dimensions in mm

Dimensions

ID	GG	IG	II	LG	LI	LL	NL	NN	RN	RR	WR
A (mm)	600	800	800	1,000	1,000	1,000	1,250	1,250	1,500	1,500	2,000
B (mm)	600	600	800	600	800	1,000	1,000	1,250	1,250	1,500	1,500
E (mm)	720	720	920	720	920	1,120	1,120	1,370	1,370	1,620	1,620
D (mm)	500	700	700	900	900	900	1,150	1,150	1,400	1,400	1,900

Height (C in mm)

Weighing range		150 kg	300 kg	600 kg	1000 kg	1500 kg	3000kg
Dimensions in mm (AxB)	ID	standard height		optional height in mm			
600x600	GG	35	25	35	25	35	25
800x600	IG	35	25	35	25	35	25
800x800	II	35	25	35	25	35	25
1,000x600	LG	35	25	35	25	35	25
1,000x800	LI	35	25	35	25	35	25
1,000x1,000	LL	35	25	35	25	35	25
1,250x1,000	NL	35	25	35	25	35	25
1,250x1,250	NN	35	25	35	25	45	35
1,500x1,250	RN	35	25	35	25	45	35
1,500x1,500	RR	45	35	45	35	45	35
2,000x1,500	WR	45	35	45	35	45	35

Dimensions ramp (F in mm)

ID	GG	IG	II	LG	LI	LL	NL	NN	RN	RR	WR
for 35 25 mm height	350	350	350	350	350	350	350	350	350	350	-
for 45 mm height	-	-	-	-	500	500	500	500	500	500	500

Single range scale resolutions

Weighing range in kg	-I 30.000 d in g	-L 15.000 d in g	-LCE 1x3.000 e verifiable in g
150	5	10	50
300	10	20	100
600	20	50	200
1,000	50	100	500
1,500	50	100	500
3,000	100	200	1,000

Multiple-range scale resolutions

-NCE 2x3.000 e verifiable				
Weighing range in kg	Weighing range 1 in kg	Resolution for Weighing range 1 in g	Weighing range 2 in kg	Resolution for Weighing range 2 in g
150	60	20	150	50
300	150	50	300	100
600	300	100	600	200
1,000	600	200	1,000	500
1,500	600	200	1,500	500
3,000	1.500	500	3,000	1,000

* Weighing range 150 kg for dimensions NN, RN, RR, WR not available as -NCE version

Weight and packaging details

ID	Dimensions in mm (AxB)	Net weight (incl. 1 ramp) in kg	Gross weight (with pallet) in kg	Ramp weight in kg	Packaging		
					Length in mm	Width in mm	Height in mm
GG	600x600	55	90	14	1,160	1,230	260
IG	800x600	65	100	14	1,160	1,230	260
II	800x800	75	110	18	1,160	1,230	260
LG	1000x600	75	110	14	1,160	1,230	260
LI	1000x800	85	120	18	1,160	1,230	260
LL	1,000x1,000	130	170	30	1,400	1,440	280
NL	1,250x1,000	140	180	30	1,400	1,440	280
NN	1,250x1,250	170	218	35	1,650	1,680	280
RN	1,500x1,250	200	248	35	1,650	1,680	280
RR	1,500x1,500	230	285	40	1,650	1,680	280
WR	2,000x1,500	270	335	40	2,150	1,900	280

Operating limits

Load capacity acc. to DIN 1925 / normal load 2

Weighing range in kg	ID	Max. overload center in kg	Max. overload side in kg	Max. overload corner in kg	Max. overload per axis for optional heights *
150	GG up to NL	300	150	75	150
150	NN up to WR	600	300	150	300
300		600	300	150	300
600		1,700	850	425	850
1,000		2,000	1,000	500	1,000
1,500		3,000	1,500	750	1,500
3,000		3,500	1,500	750	1,500

* Minimum wheel gauge of the vehicle (S in mm)

- applies to all optional profile heights 25 resp. 35 mm
- Calculation basis for min. wheel gauge: Width (B) minus 150 mm

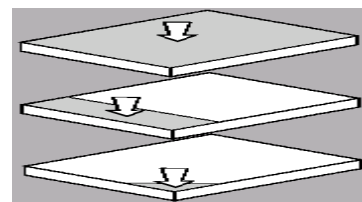

Overview Options

Standard models	Option
	T4 Drive-through protection for exclusively one-sided loading and unloading
	T13 4 transport grips on the front and rear sides
	T6 Rollers on the rear side and grips on the front side for one-sided lifting and handling
	T15 Second ramp for two-sided access and use as a drive-through scale
	T14 Support arm for attaching an electronic scale display
	T9 Cover plate for added protection of the underside of the platform with openings for the load feet
Fold-up models	
	T8 Premium folding device; com-plies with NIOSH specifications for one-person operability(required lifting force < 20 kg)
	T12 As option T8 but with second ramp for two-sided access and use as a drive-through scale
	T10 Basic folding device with folding hinge and gas-pressurized spring for 2 man operation
	T11 As option T10 but with second ramp for two-sided access and use as a drive-through scale
	T9 Cover plate for added protection of the underside of the platform with openings for the load feet
	T4 Drive-through protection for exclusively one-sided loading and unloading
Models with wheels	
	T7 4 built-in foldaway wheels which can be lowered for easy handling of platform
	T5 Steering draw bar for easy pushing, combined with drive-through protection as standard
	T4 Drive-through protection for exclusively one-sided loading and unloading
	T15 Second ramp for two-sided access and use as a drive-through scale
	T14 Support arm for attaching an electronic scale display
	T9 Cover plate for added protection of the underside of the platform with openings for the load feet

По вопросам продаж и поддержки обращайтесь:

Астана+7(7172)727-132, Волгоград(844)278-03-48, Воронеж(473)204-51-73, Екатеринбург(343)384-55-89,
 Казань(843)206-01-48, Краснодар(861)203-40-90, Красноярск(391)204-63-61, Москва(495)268-04-70,
 Нижний Новгород(831)429-08-12, Новосибирск(383)227-86-73, Ростов-на-Дону(863)308-18-15, Самара(846)206-03-16,
 Санкт-Петербург(812)309-46-40, Саратов(845)249-38-78, Уфа(347)229-48-12

sst@nt-rt.ru || sartorius.nt-rt.ru