



## IU weighing platforms Pallet scales

**По вопросам продаж и поддержки обращайтесь:**

Астана+7(7172)727-132, Волгоград(844)278-03-48, Воронеж(473)204-51-73, Екатеринбург(343)384-55-89,  
Казань(843)206-01-48, Краснодар(861)203-40-90, Красноярск(391)204-63-61, Москва(495)268-04-70,  
Нижний Новгород(831)429-08-12, Новосибирск(383)227-86-73, Ростов-на-Дону(863)308-18-15, Самара(846)206-03-16,  
Санкт-Петербург(812)309-46-40, Саратов(845)249-38-78, Уфа(347)229-48-12

**sst@nt-rt.ru || sartorius.nt-rt.ru**

## 48 basic models with customized options

### The product

IU pallet scales represent a new generation of industrial weighing equipment. From 10 g to 3,000 kg, from basic weighing to convenient, application-oriented weighing systems, from processing to the chemical industry, the IU line of pallet scales can do it all thanks to the wide range of resolutions and verifiable accuracies available. These weighing platforms are ATEX-compliant for use in various hazardous area Zone classifications. And, as if the diversity of the basic models wasn't enough, the additional custom features we can provide on request make this range truly unique.

A broad range of special equipment and features are available as options and accessories for any of the 48 basic models. The pallet scale is not only preconfigured, it is also verified at the factory for use in legal metrology at the place of installation. We can even fulfill special requests, such as the use of higher-grade materials for the platform, and much more!

### Main features

Strain-gauge technology: 4 load cells ensure precise results.

Profile: standard platform height is 76 mm

Material | surface finish: ST37 galvanized steel or bead-blasted AISI 304 stainless steel.

Resolution: scale intervals of 15,000 d, 30,000 d, 1×3000 e (single range) or 2×3000 e (multiple range) are available for all models.

IP protection: The galvanized steel platforms meet IP65 requirements; stainless steel versions are rated to IP68.

All platforms have 2 rollers and a handle for effortless mobility.

### Options

On request, stainless steel models can be delivered with an electropolished finish, or the entire platform can be made from AISI 316 Ti stainless steel.

Additional columns can be supplied on request.

Inlay plates can be supplied for weighing loads of up to 600 kg.

Special versions can be manufactured for use in IBC handling and Big Bag filling.

### For use in hazardous areas in accordance with ATEX

The stainless steel IUXS4... models are certified for use in ATEX Category 2, Zone 1 (gases) and Zone 21 (dusts) hazardous areas in accordance with KEMA – EC type-approval certificate II 2G 1D EEx ib IIC T4 T155°C IP68, and come with Verification of Intrinsic Safety that applies to other explosion-protected Sartorius components as well, such as intrinsically safe Combics indicators or Factory terminals, intrinsically safe load cell interfaces, and various transmitters.

If you order Option Y2 with an IUS4 (stainless steel) or IUG4 model (galvanized steel), the platform is rated for use in ATEX Category 3, Zone 2 (gases) and Zone 22 (dusts) hazardous areas in accordance with EN50021 with manufacturer's declaration of conformity: II 3GD EEx nA II T6 T80°C IP65/IP67, and come with Verification of Intrinsic Safety that applies to other explosion-protected Sartorius Ex components as well, such as Combics plus Option Y2, or transmitters.

# Specifications

## General View

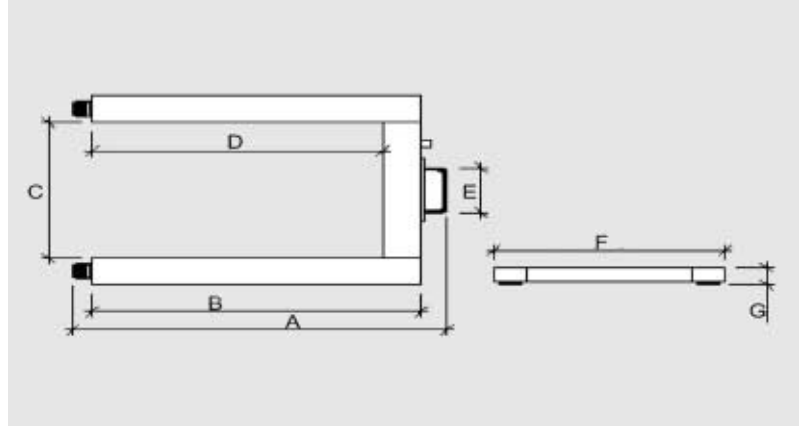

Code	A	B	C	D	E	F	G
Dimensions	1,370 mm	1,190 mm	600 mm	1,080 mm	200 mm	840 mm	76 mm

## Resolutions

### Resolution 1

#### Weighing capacity –L, -I, -LCE

Capacity in kg	15,000 d in g	30,000 d in g	1×3000 e in g
300	20	10	100
600	50	20	200
1,500	100	50	500
3,000	200	100	1,000

### Resolution 2

#### Weighing capacity –NCE 2×3000 e

Capacity in kg	Capacity 1 in kg	Resolution Range 1 in g	Capacity 2 in kg	Resolution Range 2 in g
300	150	50	300	100
600	300	100	600	200
1,500	600	200	1,500	500
3,000	1,500	500	3,000	1,000

## Features

Version: galvanized steel in IP65, or AISI 304 (optional: AISI 316 Ti electropolished) stainless steel in IP76/68

4× C 3 load cells

Overload protection

4× adjustable feet and level indicator

Allowable ambient operating temperature: -10°C to +40°C (+14°F to +104°F)

Resolutions: verifiable (legal for trade), Class I: (1×3000 e, 2×3000 e) or standard (not legal for trade): 15,000 d, 30,000 d.

The length of the cable for connecting an indicator is 6 m.

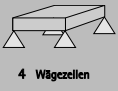
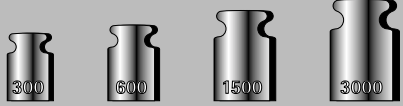
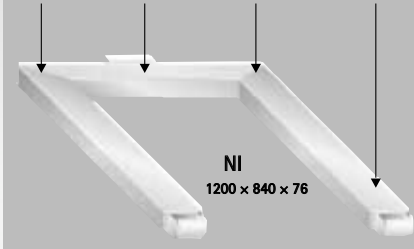

## Example for placing an order: platform model IUS4-1500NI-LCE

IU	S	4	-	1500	NI	-	LCE
Platform	Finish: G = Galvanized steel S = Stainless steel XS = Ex-protected stainless steel	No. of load cells  4 Wägezellen		Weighing capacity in kg 	Platform size		Resolution: Standard (not legal for trade): 15,000 d = L 30,000 d = I Verifiable (legal for trade): 3,000 e = LCE 2 × 3,000 e = NCE*
* Weighing capacity 150 kg not available for platform sizes NN, RN, RR or WR							

### По вопросам продаж и поддержки обращайтесь:

Астана+7(7172)727-132, Волгоград(844)278-03-48, Воронеж(473)204-51-73, Екатеринбург(343)384-55-89,  
Казань(843)206-01-48, Краснодар(861)203-40-90, Красноярск(391)204-63-61, Москва(495)268-04-70,  
Нижний Новгород(831)429-08-12, Новосибирск(383)227-86-73, Ростов-на-Дону(863)308-18-15, Самара(846)206-03-16,  
Санкт-Петербург(812)309-46-40, Саратов(845)249-38-78, Уфа(347)229-48-12

[sst@nt-rt.ru](mailto:sst@nt-rt.ru) || [sartorius.nt-rt.ru](http://sartorius.nt-rt.ru)